

Quick Start Guide

APC400 Amber Power C400 LTE Vehicle Terminal

1
Install
Your device

2
Download
Amber Connect
App

3
Activate
the device



Product overview

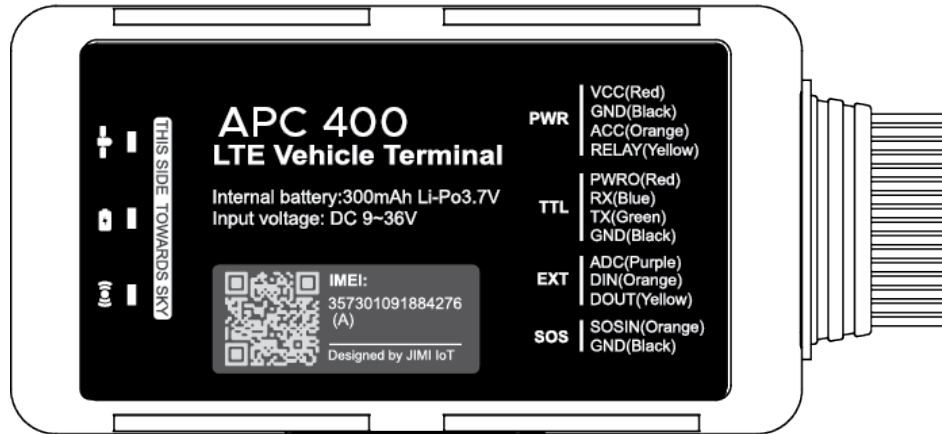

Position tracking

- GPS & LBS positioning
- Real-time location query

Anti-theft

- Ignition detection
- Power/Fuel cut-off
- SOS emergency call
- Power supply disconnection alert Geo-fence alert
- Towing alert
- Vibration alert

Configurable peripherals

- Vehicle door status alert
- Turn light/buzzer triggering
- Fuel level monitoring
- Temperature monitoring
- Driver behavior monitoring

Specification

GSM Band	B5(850MHz)/B2(1900 MHz) B8(900M Hz)/B3(1800M Hz)
LTE	B1/B2/B3/B4/B5/B12/B13/B28/B66 (APC400-LA) B1/B3/B5/B8/B18/B19/B20/B26 (APC400-E)
GNSS Type	MTK all-In-one multi-GNSS SOC
Sensitivity	Cold start: <32s Hot start: <1s
Position Accuracy (CEP50)	Autonomous: <10m
Dimensions	106mm x 56.8mm x 22mm
Weight	104g
Backup Battery	Li-Polymer, 300 mAh

Operating Voltage	9V to 36V DC
Operating Temperature	-30°C to +85°C for storage
Transmit Protocol	TCP

Product setup

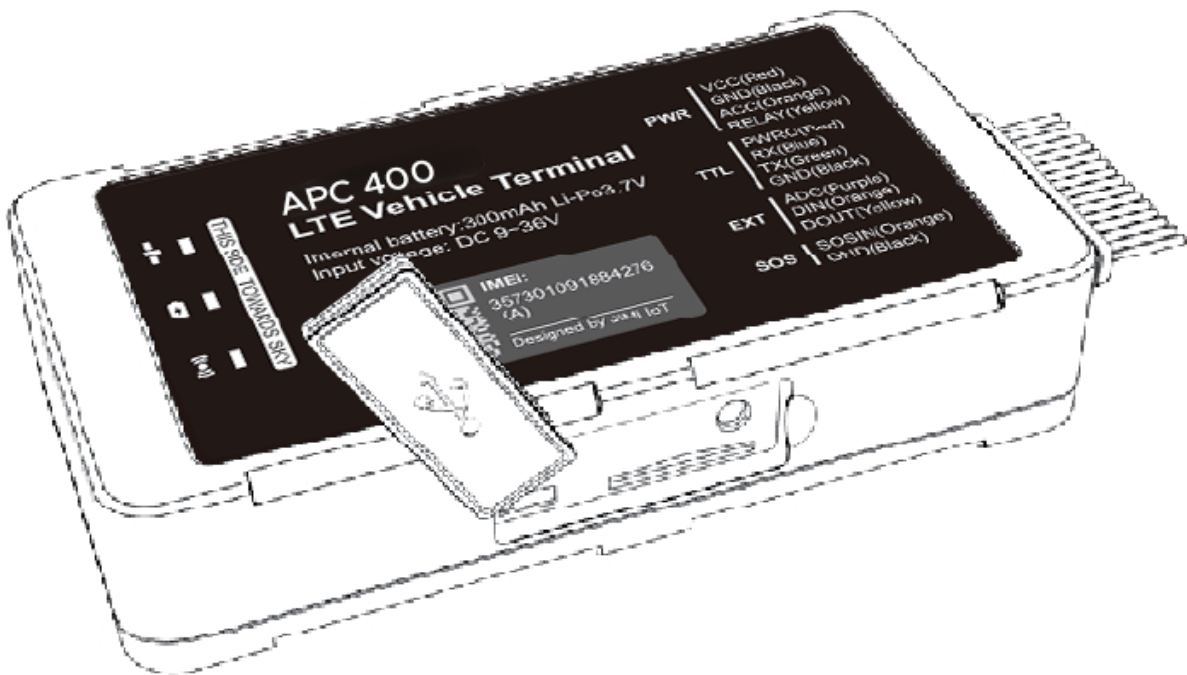

Insert SIM

Remove the soft plug on one side of the device and insert the SIM card into the card slot.

Power on & off

Toggle the power switch besides the SIM slot to power on or off the device.

LED indications

Power Status (Red)

Behaviour	Meaning
On for 0.1 s and off for 1 s	0%---20% remaining battery
On for 0.1 s and off for 4s	20%---100% remaining battery
Solid on	Power supply connected

GNSS Status (Blue)

Behaviour	Meaning
On for 0.5s and off for 0.5s	GNSS synchronizing
On for 2s and off for 4s	Positioning
On for 0.1 s and off for 4s	Positioned
Off	GNSS module is in sleep mode or not working

Wireless Network & SIM Card Status (Green}

Behaviour	Meaning
On for 0.5s and off for 0.5s	SIM card not recognized
On for 2s and off for 4s	Registered but no inbound acknowledgement
On for 0.1 s and off for 4s	Network connected
Off	No signal received or no SIM card detected

Interfaces

PWR	Red	DC 9 to 36v input
	Black	GND
	Yellow	Relay control to cut vehicle fuel support
	Orange	Vehicle ignite 12v/24v detection

TTL	Blue	TTL TX
	Green	TTL RX
	Red	DV 5v output max.500mah
	Black	GND

EXT	Purple	Analog detect 0v to 30v
	Orange	GND trigger digital input
	Yellow	Extend relay control

SOS	Orange	DC 9 to 36v input
	Black	GND

Wiring indication

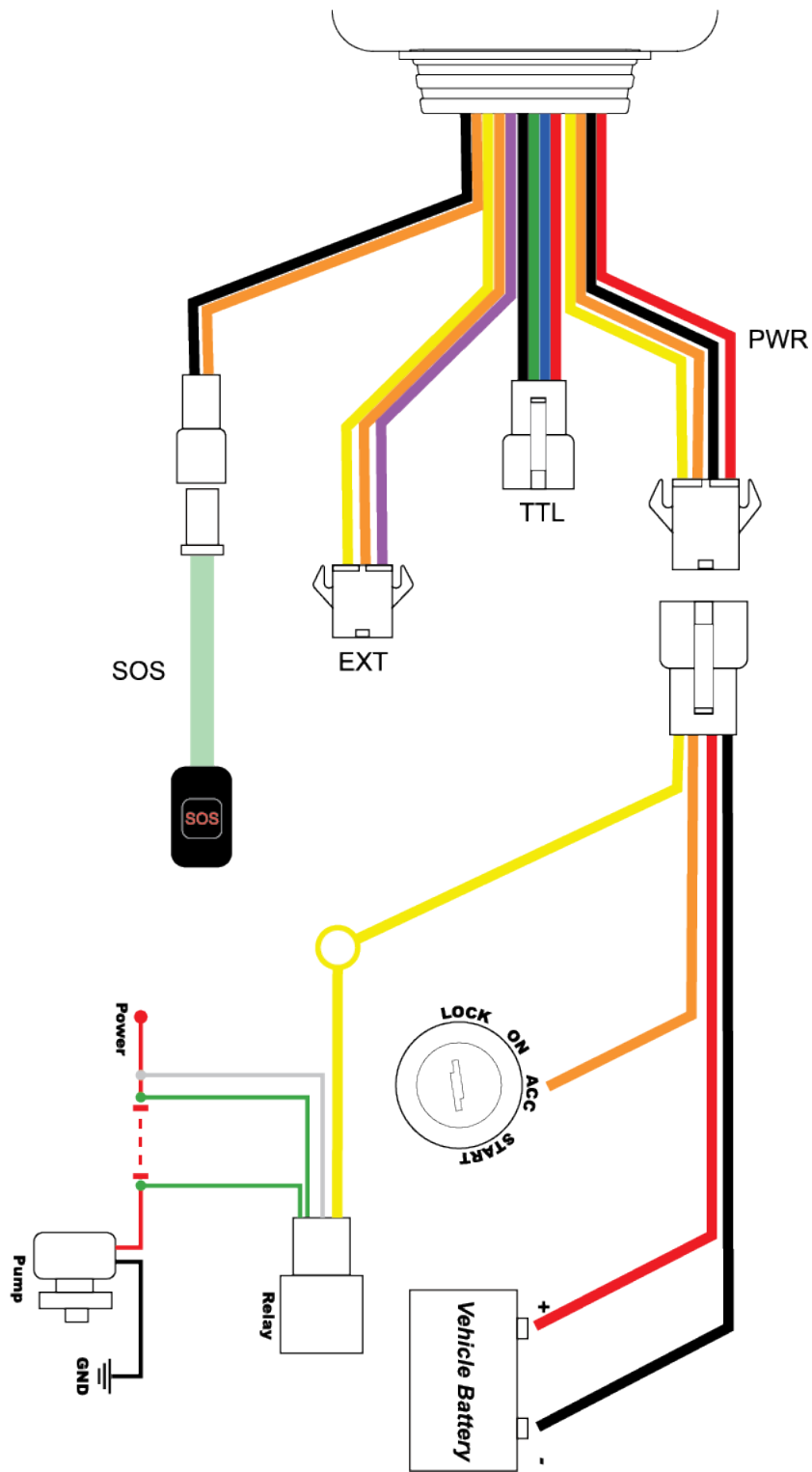

Power connection

The standard power supply ranges from 9V to 36VDC.

During installation, negative side should connect to the ground. Do not connect with other ground wires simultaneously.

Ignition wire

ACC line (orange) connects to vehicle's ACC, detecting ignition.

Be sure to check if it's a real ignition wire Le. power does not disappear after starting the engine.

Relay wiring

Relay's white line (85) connects to the positive side of battery (12V) while the yellow line (86) connects to the device relay control (yellow line on the power cord).

Find the fuel pump in the vehicle and cut off its positive power line. The positive side of fuel pump connects to the green line (87a) while the side closing to starter motor connects to green line (30), as the below chart. Switch of the two green lines have the same effect.

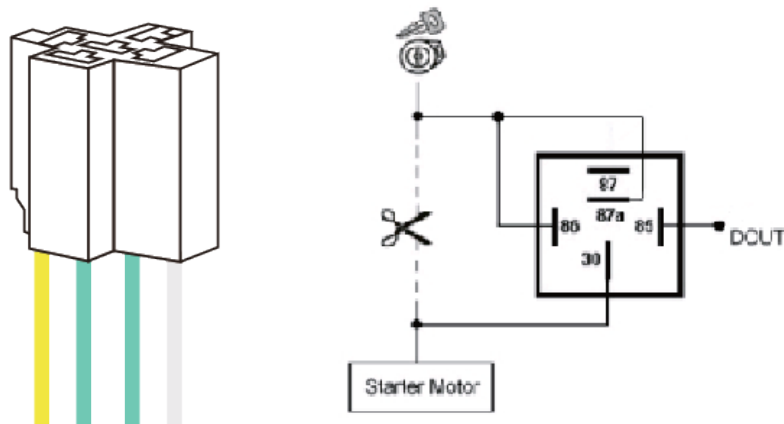

Configuration

If you need to change the setting of the device, you can either text the command to the device, or use PC tool from supplier.

Note:

Texting command might be filtered by local carrier network deployment. In this case you can text through web management center provided by the carrier.

Package & Standard accessories

- Standard package
- APC400 device
- Power cable
- 1/0 cable
- Relay (12V/24V)
- SOS button cable

Installation recommendation

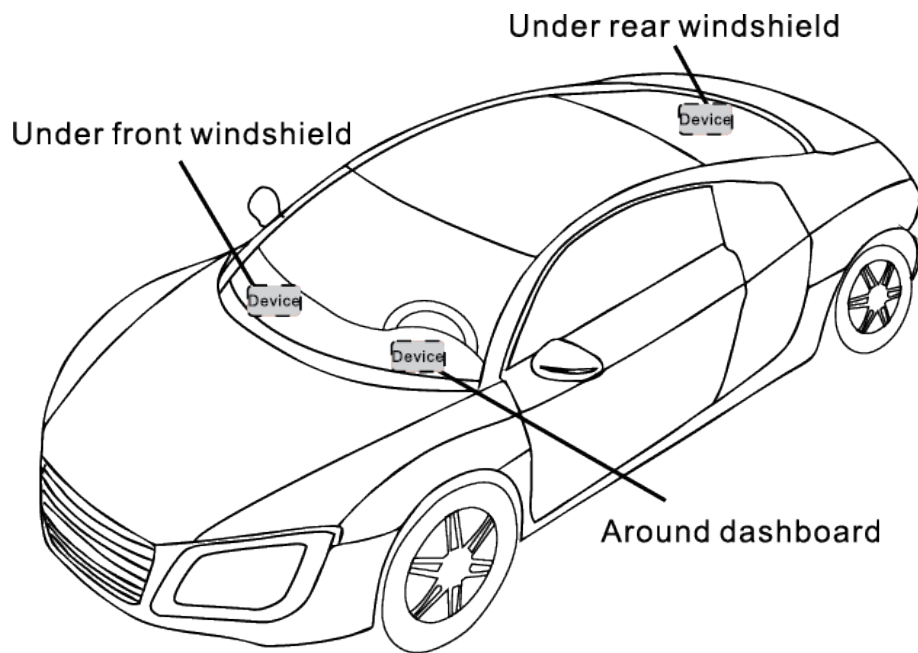

- The device should face up to the sky.
- Metal thermal barrier or heating layer of the windshield affects the signal.

Troubleshooting

Type	Use
Unable to connect to tracking platform	Check the APN and IP settings. Check whether the data service of SIM card is enabled. Check the balance of SIM card.
Tracker shows offline	Check whether external power is still connected. Check if the vehicle entered network blind area. Check the balance of SIM card.
Unable to locate	Make sure the top side facing upward without metallic things shielded. Make sure it's not in area with no satellite coverage.
Location drift	In area with poor GNSS signal (tall building around or basement), drifting may happen. Check whether vibration happens around to trigger the accelerator.
No command reply	Make sure command format is correct. Vehicle may be in network blind area. Make sure SIM card is well inserted and has SMS service.

Warranty instructions

1. The warranty is valid only when the warranty card is property completed, and upon presentation of the proof of purchase consisting of original invoice indicating the date of purchase, model and serial No. of the product. We reserve the right to refuse warranty if this information has been removed or changed after the original purchase of the product from the dealer.
2. Our obligations are limited to repair of the defect or replacement the defective part or at its discretion replacement of the product itself.
3. Warranty repairs must be carried out by our Authorized Service Centre. Warranty cover will be void, even if a repair has been attempted by any unauthorized service centre.
4. Repair or replacement under the terms of this warranty does not provide right to extension or renewal of the warranty period.
5. The warranty is not applicable to cases other than defects in material, design and workmanship



Need help? Contact 24/7 live support!

 In App Chat

 support@amberconnect.com

 Chat via website www.amberconnect.com

Works with Android phones and tablets, iPhone, iPad.
Compatible with Chrome, Mac and PC web browsers.



Scan this QR code to download your App



Amber Connect

© 2024 Amber Connect Limited. All rights reserved