

Quick Start Guide

AGT200

Amber Govern T200

Professional GNSS/GSM Terminal

1
Install
Your device

2
Download
Amber Connect
App

3
Activate
the device



Know your device

Top view



2x10 Socket

Top view
(without cover)

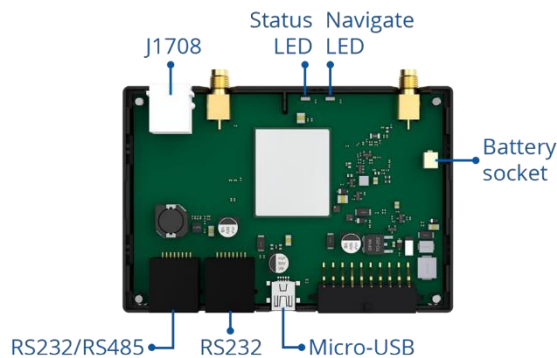

AGT 200 Device view

Bottom view
(without cover)

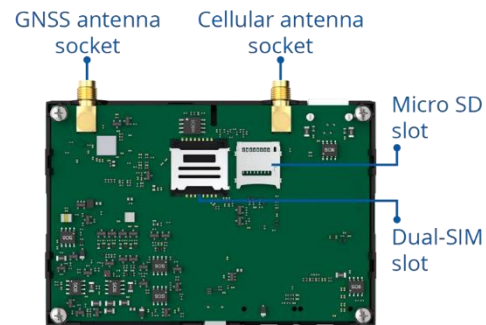

Pinout



AGT200 pinout

Pin number	Pin name	Description
1	GND (-)	Ground
2	CAN 1L	SAE J1939 CAN interface Low channel 1
3	1WIRE POWER	Power supply pin for Dallas 1-Wire® devices
4	DIN4	Digital input, channel 4
5	DIN2	Digital input, channel 2
6	CAN 2L	SAE J1939 CAN interface Low channel 2
7	AIN2	Analog input, channel 2. Input range: 0-30V/0-10V DC
8	DOUT3	Digital output. Open collector output
9	DOUT2	Digital output. Open collector output
10	AIN3	Analog input, channel 3. Input range: 0-30V/0-10V DC
11	VCC (+)	Power supply (+10-30 V DC)
12	CAN 1H	SAE J1939 CAN interface High channel 1
13	1WIRE DATA	Data channel for Dallas 1-Wire® devices

14	DIN3	Digital input, channel 3
15	IGN (DIN1)	Digital input, channel 1. DEDICATED FOR IGNITION INPUT
16	CAN 2H	SAE J1939 CAN interface High channel 2
17	AIN1	Analog input, channel 1. Input range: 0-30V/0-10V DC
18	DOUT4/AIN4	Digital output. Open collector output OR Analog input, channel 4. Input range: 0-30V/0-10V DC
19	DOUT1	Digital output channel 1. Open collector output
20	K-Line	K-LINE interface for online Tachograph Vehicle Data transfer

Wiring scheme

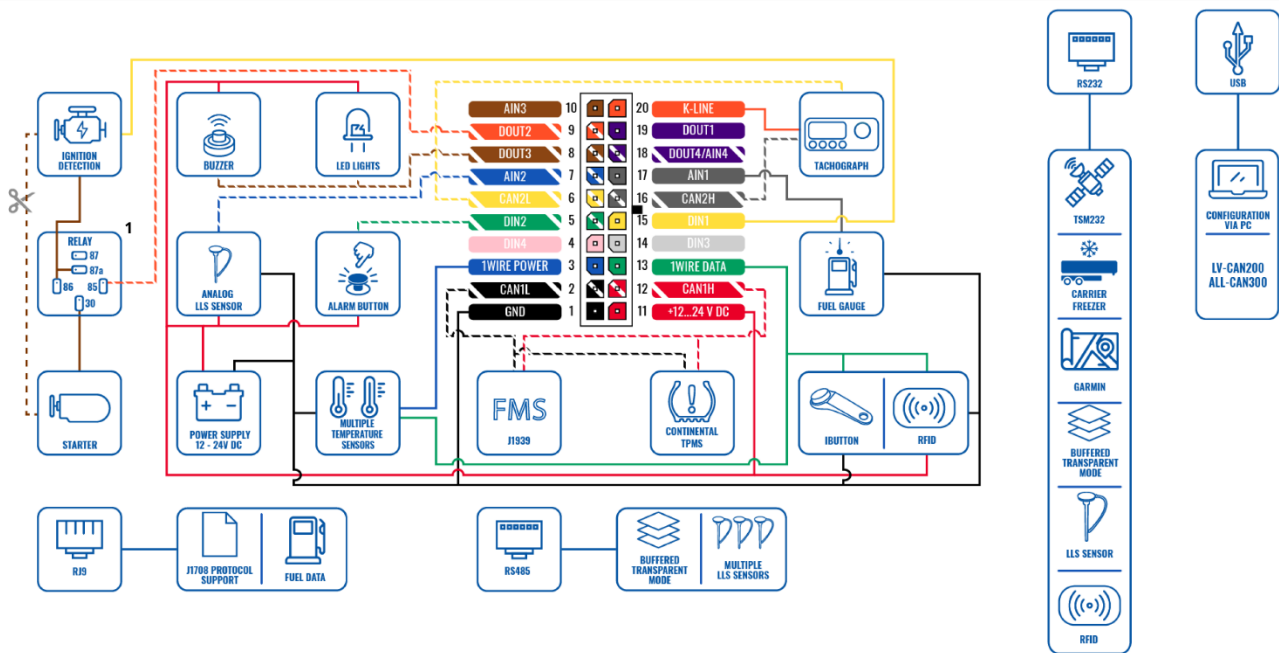

AGT 200 Wiring scheme

Set up your device

How to insert Micro-SIM card and connect the battery

1. Unscrew 4 screws counter clockwise that are located on the bottom of the device.
2. Remove the cover.
3. Insert SIM card as shown with PIN request disabled or read Security info how to enter it later in Amber Configurator. Make sure that SIM card cut-off corner is pointing forward to slot. SIM slot 1 is closer to PCB, SIM slot 2 is the upper one.
4. Connect battery as shown to device.
5. After configuration, see "PC Connection (Windows)", attach device cover back
6. Screw in all screws. Device is ready to be mounted.

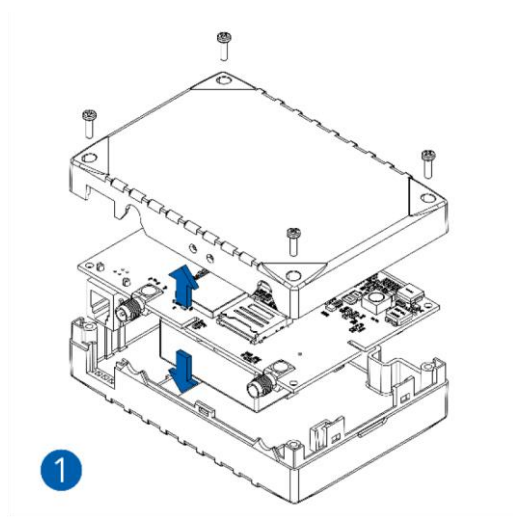

Unscrew screws

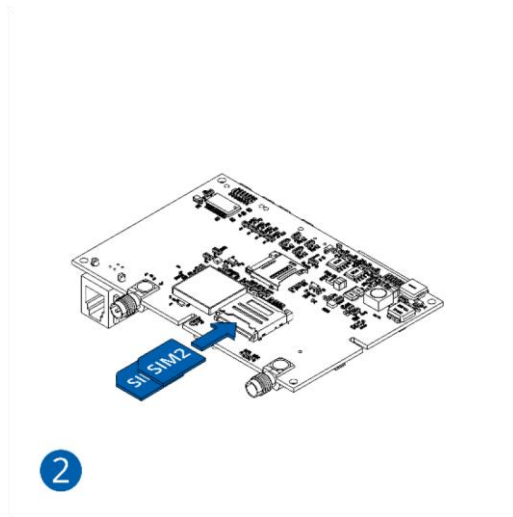

Cover removal

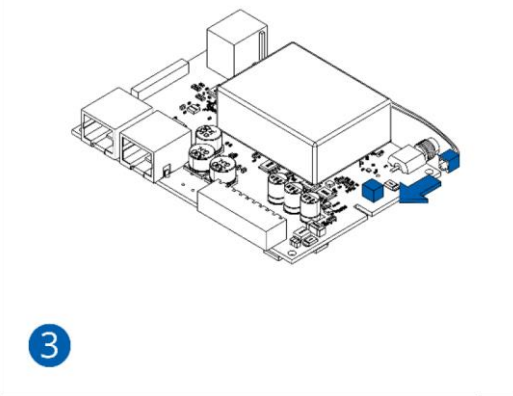

SIM card insert

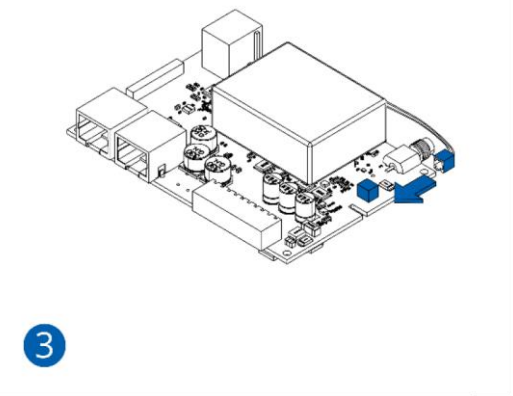

Battery connection

Mounting recommendations

• Connecting wires

1. Wires should be connected while the module is not plugged in.
2. Wires should be fastened to the other wires or non-moving parts. Try to avoid heat emitting and moving objects near the wires.
3. The connections should not be seen very clearly. If factory isolation was removed while connecting wires, it should be applied again.
4. If the wires are placed in the exterior or in places where they can be damaged or exposed to heat, humidity, dirt, etc., additional isolation should be applied.
5. Wires cannot be connected to the board computers or control units.

• Connecting power source

1. Be sure that after the car computer falls asleep, power is still available on chosen wire. Depending on car, this may happen in 5 to 30 minutes period.
2. When the module is connected, measure the voltage again to make sure it did not decrease.
3. It is recommended to connect to the main power cable in the fuse box.

4. 3 A, 125 V external fuse

• Connecting ignition wire

1. Be sure to check if it is a real ignition wire power does not disappear while starting the engine.
2. Check if this is not an ACC wire (when key is in the first position, most electronics of the vehicle are available).
3. Check if power is still available when you turn off any of vehicles devices.
4. Ignition is connected to the ignition relay output. As alternative, any other relay, which has power output when ignition is on, may be chosen.

• Connecting ground wire

1. Ground wire is connected to the vehicle frame or metal parts that are fixed to the frame.
2. If the wire is fixed with the bolt, the loop must be connected to the end of the wire.
3. For better contact scrub paint from the spot where loop is going to be connected.



PAY ATTENTION! Connecting the power supply must be carried out in a very low impedance point of on-board vehicle network. Connecting the GND at an arbitrary point to the mass of the car is unacceptable, as static and dynamic potentials on the line GND will be unpredictable, which can lead to unstable AGT400-M operation and even its failure.

LED indications

Navigation LED indications

Behaviour	Meaning
Permanently switched on	GNSS signal is not received
Blinking every second	Normal mode, GNSS is working
Off	GNSS is turned off because: Device is not working or Device is in sleep mode
Blinking fast constantly	Device firmware is being flashed

Status LED indications

Behaviour	Meaning
Blinking every second	Normal mode
Blinking every two seconds	Sleep mode
Blinking fast for a short time	Modem activity
Off	Device is not working or Device is in boot mode

Characteristics

Basic characteristics

Module	
Name	AGT 200
Technology	GSM ,GPRS, GNSS, BLUETOOTH

GNSS	
GNSS	GPS, GLONASS, GALILEO, BEIDOU, QZSS, DGPS
Receiver	Tracking: 33/99 acquisition channels
Tracking sensitivity	-165 dBm
Accuracy	< 3 m
Hot start	< 1 s
Warm start	< 25 s
Cold start	< 35 s

Cellular	
Technology	GSM/GPRS
2G bands	Quad-band 850/900/1800/1900 MHz
GPRS	GPRS Mobile Station Class B
Data transfer	GPRS Multi-Slot Class 12 (up to 240 kbps)
Data support	SMS (text/data)

Power	
Input voltage range	10-30 V DC with overvoltage protection
Back-up battery	550 mAh 8,4V Ni-MH battery
2 W max. Current consumption at 12 V	GPRS: average 69 mA Nominal: average 39 mA GNSS sleep: average 24 mA Deep Sleep: average 7.5 mA Online Deep Sleep: average 2.4 mA
2 W max. Current consumption at 24 V	GPRS: average 35 mA Nominal: average 20 mA GNSS sleep: average 12,5 mA Deep Sleep: average 3,8 mA Online Deep Sleep: average 1.3 mA

Interface	
Digital Inputs	4
Digital Outputs	4
Analog Inputs	4
1-Wire temperature sensors	6
1-Wire iButton	1
RS232	2
RS485	1
CAN J1939	2
J1708	1
K-Line	1
LVCAN/ALLCAN	1
GNSS antenna	External High Gain
GSM antenna	External High Gain
USB	2.0 Mini-USB
LED indication	2 status LED lights
SIM	2x SIM Card (Dual-SIM)

Memory	2MB internal flash memory and Micro-SD card
Bluetooth	
Specification	4.0 + LE
Supported peripherals	Headset, Inateck Barcode Scanner
Features	
Sensors	Accelerometer
Scenarios	Green Driving, Over Speeding detection, Jamming detection, Excessive Idling detection, Crash detection, Immobilizer, iButton Read Notification, Towing detection,
Functionalities	Crash detection, Auto Geofence, Manual Geofence, Trip Detection, Odometer, DDD download and Tacho Online Data
Sleep modes	GPS Sleep, Online Deep Sleep, Deep Sleep
Configuration and firmware update	FOTA Web, FOTA, Amber Configurator (USB, Bluetooth), FMBT mobile application (Configuration)
SMS	Configuration, Events, DOUT control, Debug
GPRS commands	Configuration, DOUT control,
Time Synchronization	GPS, NITZ, NTP
Fuel monitoring	LLS (Analog), LV-CAN, ALL-CAN, CAN FMS, RS232/RS485 Fuel Sensor, Ultrasonic level sensor
Ignition detection	Digital Input , Accelerometer, External Power Voltage
Physical specification	
Dimensions	104,1 x 76,8 x 31,5 mm (L x W x H)
Weight	197 g

Operating environment	
Operating temperature (without battery)	-40 °C to +85 °C
Storage temperature (without battery)	-40 °C to +85 °C
Operating humidity	5% to 95% non-condensing
Ingress Protection Rating	IP41

Electrical characteristics

Characteristic description	Value			Unit
	Min.	Typ.	Max.	
Supply Voltage				
Supply Voltage (Recommended Operating Conditions)	+10		+30	V
Digital Output (Open Drain grade)				
Drain current (Digital Output OFF)			120	µA
Drain current (Digital Output ON, Recommended Operating Conditions)			0.5	A
Static Drain-Source resistance (Digital Output ON)		400	300	mΩ

Digital Input				
Input resistance (DIN1)	15			kΩ
Input resistance (DIN2)	15			kΩ
Input resistance (DIN3)	15			kΩ
Input resistance (DIN4)	15			
Input voltage (Recommended Operating Conditions)	0		Supply voltage	V
Input Voltage threshold (DIN1, DIN2, DIN3, DIN4)		7.5		V
Input Voltage threshold (DIN2, DIN3, DIN4)		7.5		V

Analog Input				
Input voltage (Recommended Operating Conditions), Range 1	0		+10	V
Input resistance		120		kΩ
Input Voltage (Recommended Operating Conditions), Range 2	0		+30	V
Input resistance		147		kΩ
1-Wire				
Supply voltage	+3.3		+3.9	V
Output inner resistance		7		Ω
Output current ($U_{out} > 3.0$ V)		30		mA
Short circuit current ($U_{out} = 0$)		75		mA

CAN Interface				
Internal terminal resistors CAN bus		120		Ω
Differential input resistance	19	30	52	kΩ
Recessive output voltage	2	2.5	3	V
Differential output voltage	0.5	0.7	0.9	V
Common mode input voltage	-30		30	V

Safety information

This message contains information on how to operate AGT 200 safely. By following these requirements and recommendations, you will avoid dangerous situations. You must read these instructions carefully and follow them strictly before operating the device!

- The device uses SELV limited power source. The nominal voltage is +12 V DC. The allowed voltage range is +10...+30 V DC.
- To avoid mechanical damage, it is advised to transport the device in an impact-proof package. Before usage, the device should be placed so that its LED indicators are visible. They show the status of device operation.
- When connecting the 2x10 connector wires to the vehicle, the appropriate jumpers of the vehicle power supply should be disconnected.
- Before dismounting the device from the vehicle, the 2x10 connector must be disconnected.
- The device is designed to be mounted in a zone of limited access, which is inaccessible to the operator. All related devices must meet the requirements of EN 62368-1 standard.
- The device AGT 200 is not designed as a navigational device for boats.



Do not disassemble the device. If the device is damaged, the power supply cables are not isolated or the isolation is damaged, DO NOT touch the device before unplugging the power supply.



All wireless data transferring devices produce interference that may affect other devices which are placed nearby.



The device must be connected only by qualified personnel.



The device must be firmly fastened in a predefined location.



The programming must be performed using a PC with autonomic power supply.



Installation and/or handling during a lightning storm is prohibited.



The device is susceptible to water and humidity.

Certification and Approvals

- AGT400-M CE / RED
- AGT400-M CE E-Mark
- AGT400-M CE REACH
- AGT400-M CE Declaration of IMEI assignment
- AGT400-M CE Declaration of device operation temperature
- AGT400-M CE RoHS
- AGT400-M CE EAC



This sign on the package means that it is necessary to read the User's Manual before your start using the device. Full User's Manual version can be found in our [Wiki](#).



This sign on the package means that all used electronic and electric equipment should not be mixed with general household waste.



Hereby, Amber declare under our sole responsibility that the above described product is in conformity with the relevant Community harmonization: European Directive 2014/53/EU (RED).

Warranty

Amber connect guarantees its products to be free of any manufacturing defects for a period of **24 months**. With additional agreement we can agree on a different warranty period, for more detailed information please contact our sales manager.

All batteries carry a reduced 6 month warranty period.

If a product should fail within this specific warranty time, the product can be:

- Repaired
- Replaced with a new product
- Replaced with an equivalent repaired product fulfilling the same functionality
- Amber can also repair products that are out of warranty at an agreed cost.

Warranty Disclaimer

Amber products are intended to be used by persons with training and experience. Any other use renders the limited warranties expressed herein and all implied warranties null and void and same are hereby excluded. also excluded from this limited warranty are any and all incidental or consequential damages including but not limited to, loss of use or revenue, loss of time, inconvenience or any other economic loss.



Need help? Contact 24/7 live support!

 In App Chat

 support@amberconnect.com

 Chat via website www.amberconnect.com

Works with Android phones and tablets, iPhone, iPad.
Compatible with Chrome, Mac and PC web browsers.



Scan this QR code to download your App



Amber Connect

© 2024 Amber Connect Limited. All rights reserved